

CF EURO 6 SERIES CABS

EXTERIOR



The distribution cab

The exterior of the new CF cab features the same conspicuous styling elements as were introduced with the new XF cab. The most dominant is the impressive grille with wide horizontal cooling openings and a chromium plated upper section with DAF logo.

The modern appearance of the cab is supported by rounded cab edges, new head lights and a stylish bumper, made of galvanised steel.

The tapered cab shape has been retained for maximum manoeuvrability in confined areas and easy driving in dense traffic. Various cab executions are available in order to specifically adapt the CF Euro 6 vehicles to their applications.

The full 2.50 m width over the mudguards gives an optimum aerodynamic fit with the superstructure or semi-trailer.

Large access steps and handgrips make windscreen cleaning easy and safe. With the standard telescopic windscreen wiper and de-icer cleaning can even be performed while standing on the ground.

Aerodynamics

Air management kits for the DAF new CF improve the aerodynamic efficiency and therefore reduce the fuel consumption. The net result is more earnings per kilometre. They also enhance the overall appearance of the vehicle and thus contribute to a positive image of the operator.

The air management options for the new CF Day Cab, Sleeper Cab and Space Cab include fixed or adjustable roof spoilers and side collars.

Chassis side skirts for tractor models may complement the cab aerodynamics.



CF EURO 6 SERIES CABS

DIMENSIONS

Day Cab



PX-7 / MX-11



MX-13

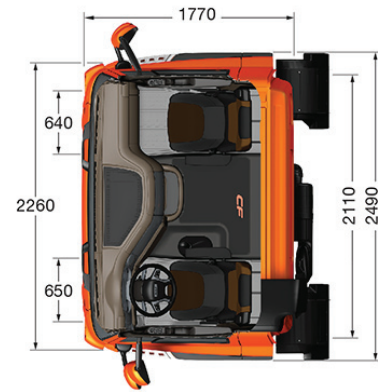

Sleeper Cab



PX-7 / MX-11



MX-13

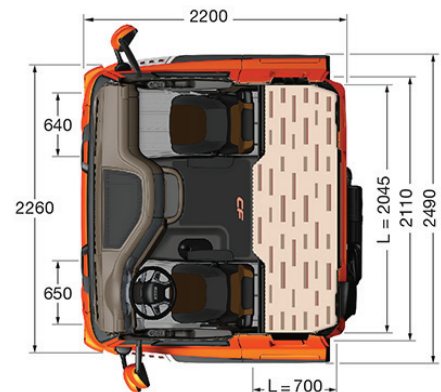

Space Cab

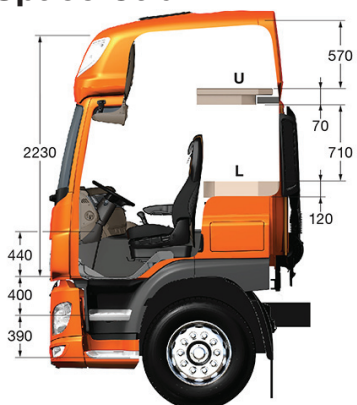

PX-7 / MX-11

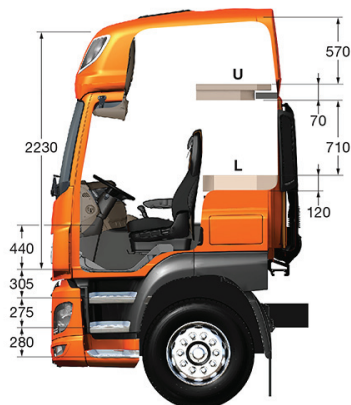

MX-13

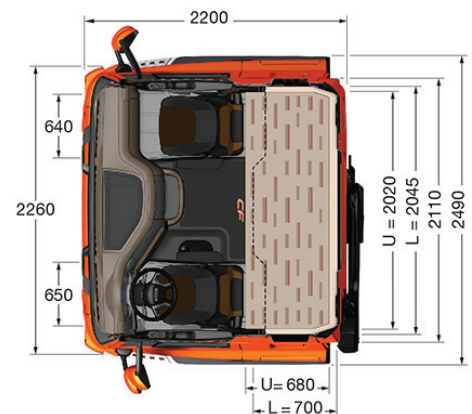

CF EURO 6 SERIES CABS

INTERIOR



Keep the good things, add even more

Although the basic shape of the CF cabs was retained in the Euro 6 cabs, a lot of changes were introduced to bring the cab interior as a whole on a much higher level. The result is an inviting interior, which convenient arrangement will immediately please every driver.

Interior trim

Bright colour schemes, a choice from three different styles of dashboard and door trimming, and new materials give the new CF cab a fresh, modern appearance. Dashboard panels without visible screw fixations and tight gaps between the dashboard panels also emphasize the quality of the CF Euro 6 cab interior.

Driving

The dashboard features new switches, a multifunctional main lighting switch and an instrument panel in which the 5 inch full colour TFT display with Driver Performance Assistant immediately attracts attention. Switches with similar functions have been grouped together for easy reference. The dashboard wing contains a double-DIN slot, a new, stylish park brake handle and a new heating control panel.

Foot pedals

The new CF cab features hanging pedals for the clutch (if applicable), service brake and accelerator. The clutch pedal was placed close to the cab floor to provide the best possible drive-off control. The other two pedals are positioned to enable easy change from accelerator to brake and back. An additional advantage is easy cleaning of the area.

Seats



Apart from a different seat upholstery, new functions were introduced for the seats in the new CF cab. Adjustable shoulder adjustment was added for both the Luxury Air and the Super Air seats. The Super Air seat also features active seat ventilation. For maximum comfort, the air is sucked away, rather than blown through the seat cushions.

Auxiliary heating

The ducting of the air-to-air auxiliary heater provides an optimum distribution of the hot air through the cab, with air outlets on both sides of the engine tunnel and on the engine tunnel itself.

CF EURO 6 SERIES CABS

SPECIFICATIONS

	Day Cab	Sleeper Cab	Space Cab
			
Cab suspension:			
Mechanical	●	●	●
Air	○	○	○
Lights:			
LED Daytime Running Lights	●	●	●
LED headlights	○	○	○
Fog lights and cornering lights	○	○	○
Skylights	-	-	○
Cab interior:			
Interior trim colour	Earth*	Earth*	Earth*
Interior decoration	Standard*	Standard*	Standard*
Driver Performance Assistant (DPA)	●	●	●
Driver seat	Comfort Air*	Comfort Air*	Comfort Air*
Co-driver seat	Basic*	Basic*	Basic*
Third seat	○	-	-
Storage box on engine tunnel	●	-	-
Refrigerator	-	○	○
Lower bed - Xtra Comfort mattress	-	○	○
Air conditioning	●	●	●
Automatic temperature control**	○	○	○
Leather steering wheel	○	○	○
Auxiliary heater / timer	○	○	○
Roof hatch	●*	●*	●*
Truck Navigation Radio (TNR)	○	○	○
Cab exterior:			
Electrically adjustable and heated main mirrors	●	●	●
Sun visor	○	○	○
Lower cab area in cab colour	○	○	○
Mirrors covers in cab colour	○	○	○

** = Basic with MX-11 engine

* = More variants available

● = basic

○ = optional

- = not applicable

Depending on the vehicle configuration a specific option may not be possible. The availability and specification may differ per country. For further information please contact the DAF organisation. Subject to modification without prior notice.